



PRODUCT RANGE

OCCUPANCY DETECTOR - CEILING MOUNTED

PART NUMBER

NL5701B THREE WIRE

USAGE

The Occupancy Detector sensor has been designed to switch lighting, heating and ventilation loads up to 10A. The unit is switched on by the detection of moving infra red heat within a specified range. When infra red heat, such as a moving body, is no longer detected, the unit will switch off the load after the adjustable time period has elapsed. If infra red heat is detected again during the timing period, the timing sequence will restart. The unit has a lux level adjustment and Auto Lux function, which measures the ambient light levels and prevents lighting being switched on, when there is sufficient lighting in the room. There is a sensitivity adjustment and test mode function added for your convenience.

The Ceiling Mount Occupancy Detector comes with surface and flush mounted options. It also has interchangeable white and chrome fascias.

A power factor correction capacitor of 4 microfarads will often be required when NewlecNL5705A switching low wattage loads, e.g. LED loads. The capacitor is fitted across switch live and neutral.

KEY FEATURES

- Rating at 240V AC 50Hz
- All load types 10A
- Time Delay 2min - 1h
- Sensitivity Adjustment
- Test Mode
- Auto and Manual Lux Sensor for Daylight Control

DO NOT INSULATION RESISTANCE TEST THIS PRODUCT. REMOVE BEFORE TESTING OR TEST CIRCUIT PRIOR TO FITTING
CAREFUL POSITIONING IS ESSENTIAL TO OBTAIN OPTIMUM PERFORMANCE

TECHNICAL DETAILS

Use the detection range to determine a suitable location for the sensor. When locating the position of the units, ensure the sensor is not subjected to bright or direct sunlight or in areas with high reflective surfaces. Do not site units on a vibrating surface, or near forced air heating and ventilation. They should not be placed within 1 metre of the load. Sensors work when objects move across their field of view. Position the sensor where people will be detected walking across the zones rather than towards the zones identified in Diagram 1. Adjust sensitivity to suit the area that the sensor has been installed in.

Diagram 1

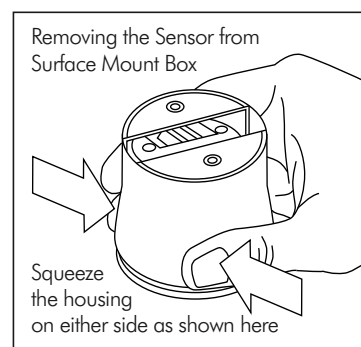
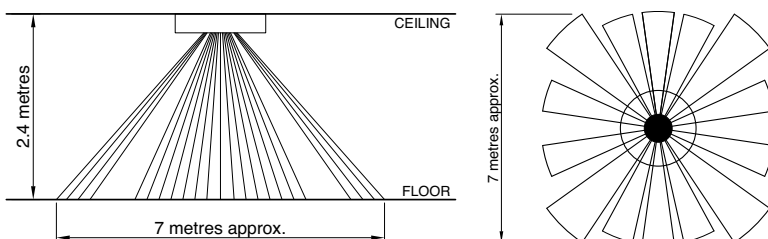

IMPORTANT NOTICE

All wiring should be carried out by a competent person or a qualified electrician and should be fitted to IEE Wiring regulations BS7671. The circuit should be isolated before carrying out any work. Failure to adhere to the instructions will invalidate the warranty.

Diagram 2

Wiring diagram for a single unit.

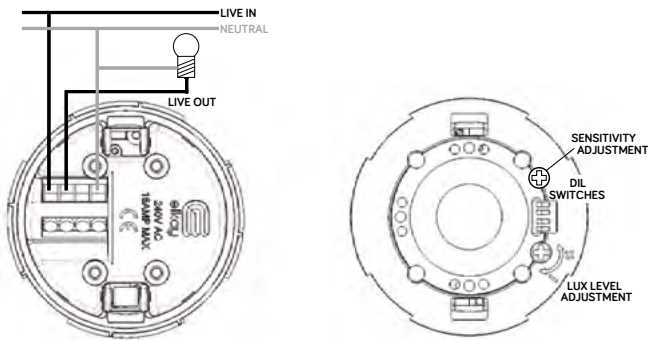

There are now 2 neutral terminals - one or both can be used.

Wiring diagram for wiring multiple devices together.

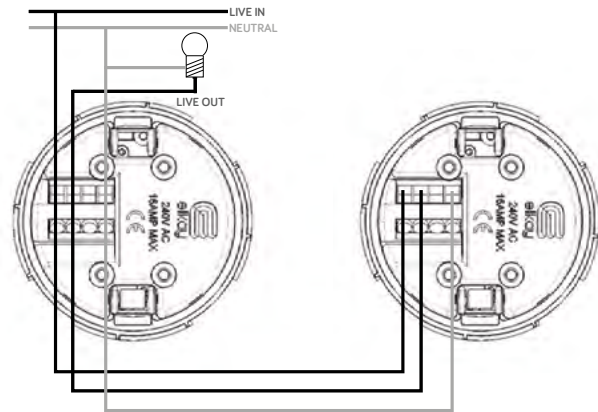

IT IS ESSENTIAL THAT YOU FOLLOW CLOSELY STEPS 1 TO 8 OF THE MOUNTING AND INSTALLATION INSTRUCTIONS BELOW. FAILURE TO DO SO WILL INVALIDATE THE WARRANTY

MOUNTING AND INSTALLATION

STEP 1 Please ensure that you position the Occupancy Detector in the correct place by reading the Positioning section of these instructions. For flush mounting cut a clean hole measuring 64mm in diameter in the chosen area for the sensor. For surface mounting attach surface mount cup to ceiling with connection cable hanging through the middle. Seal any large holes on ceiling to prevent air current activation.

STEP 2 Ensure that the mains power to the circuit is switched off. Ensure terminal cover and cable clamp are correctly fitted with screws supplied. Place the Live In into the Terminal marked Live In and the switched Live Out into the Live Out terminal. Place the neutral into the connection marked N for neutral. Please note that it is essential that the Live In wire and the switch Live Out and Neutral are identified prior to commencing installation. To connect multiple units connect the live switch live and neutrals as shown in Diagram 2. Turn off mains supply for installation as live working is not recommended and can damage the unit.

STEP 3 For flush mounting fold the two arms up into the vertical position and insert unit into the hole. Release unit ensuring arms are securely in place. For surface mounting fit surface mount cup onto ceiling or conduit terminal box and return connected Occupancy Detector into surface mount cup.

STEP 4 Remove the fascia by turning anti-clockwise to show the lux pot, sensitivity pot and the timing/lux Dip switches. Please adjust the Lux Level and Sensitivity potentiometer gently without force as this is a sensitive electronic part. After adjustment please wait 30 seconds for changes to take effect. It is recommend the product is set up initially using the 10 secs walk test mode.

STEP 5 To set Auto Lux (150 Lux) switch Dip switch 4 to the ON position. This will allow activation of the Occupancy Detector from Dusk until Dawn only. To set manually then put dip switch 4 off and use the potentiometer to adjust to desired lux level setting. All the way to the plus setting will allow the Occupancy Detector to switch day and night. All the way to the minus sets the timer to ZERO lux and effectively switches off the Occupancy Detector. To set manually you will need to be present at dusk. (See Diagram 3).

IMPORTANT NOTICE

All wiring should be carried out by a competent person or a qualified electrician and should be fitted to IEE Wiring regulations BS7671. The circuit should be isolated before carrying out any work. Failure to adhere to the instructions will invalidate the warranty.

Diagram 3

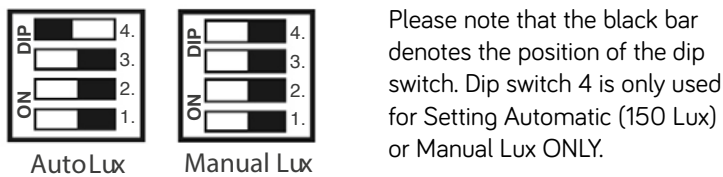

Diagram 4

Time Settings (Test Mode to 60 mins)



STEP 6 To adjust sensitivity turn anti-clockwise to the High (H) setting to increase sensitivity and clockwise to the Low (L) to decrease sensitivity.

STEP 7 To set time please utilise the dip switch timing diagram above. The black bar denotes dip switch position. Replace fascia ring by turning anti clockwise (See Diagram 4).

STEP 8 The Occupancy Detector will take approximately 2½ minutes to initialise and will flash rapidly after the mains power is first applied to allow the sensor to learn its environment. The load will be ON after 7 seconds initially, then switch off after 2½ minutes if there is no detection in the zones.

OPERATION

In standard operation the Occupancy Detector will now sense infra red heat when a person or source of heat passes through the detection zone. Each time the Occupancy Detector is triggered it will reset the timer back to the start of the timing period. The unit will then wait 5 seconds before allowing the Occupancy Detector to sense and re trigger the timing period again.

If no one is present in the room or the detection zone is not passed through, during its set time period, the timer will time out, turning off the lights or appliance.

The Occupancy Detector unit will only trigger the lights or appliance if the ambient light level is below that set on the lux level adjustment.

POSITIONING

CAREFUL POSITIONING IS ESSENTIAL TO OBTAIN OPTIMUM PERFORMANCE

Use the detection range to determine a suitable location for the sensor. When locating the position of the units, ensure the sensor is not subjected to bright or direct sunlight or in areas with high reflective surfaces. Do not site units on a vibrating surface, or near forced air heating and ventilation. They should not be placed within 1 metre of the load. Sensors work when objects move across their field of view. Position the sensor where people will be detected walking across the zones rather than towards the zones identified in diagram 1. Adjust sensitivity to suit the area that the sensor has been installed in.

IMPORTANT NOTICE

All wiring should be carried out by a competent person or a qualified electrician and should be fitted to IEE Wiring regulations BS7671. The circuit should be isolated before carrying out any work. Failure to adhere to the instructions will invalidate the warranty.

TROUBLESHOOTING GUIDE

BEFORE CALLING TECHNICAL HELP WE RECOMMEND THAT YOU ATTEMPT TO RESOLVE THE ISSUE FOR YOURSELF WITH THIS HANDY TROUBLESHOOTING GUIDE

Issue	Problem and Resolution
Load will not switch OFF	<ul style="list-style-type: none"> • Check terminal connections. • Check time settings (See Diagram 4). • Occupancy Detector is too close to load - Re-position away from lighting, heating and forced air ventilation. • Occupancy Detector is switching low wattage or LED loads - Fit Capacitor as stated in instructions NL5705A. • Windy weather conditions - Adjust Sensitivity down. • Occupancy Detector is re triggered - Check area is left unoccupied for longer that time setting using an accurate time piece. • Sensitivity set too high - Gradual incremental adjustments towards the low setting to resolve the issue.
Load will not switch ON	<ul style="list-style-type: none"> • Check terminal connections. • Lux set too low - Turn off Auto Lux and turn UP lux level to the PLUS (+) setting and wait for sensor to adjust. • Sensitivity set too low- Gradual incremental increases towards the High setting to resolve the issue.
Load switches OFF and then immediately comes back ON	<ul style="list-style-type: none"> • Check terminal connections. • Occupancy Detector is detecting normally- Find source that is triggering Occupancy Detector. • Occupancy Detector is seeing infra red heat from the load- Re-position away from heat source (See Positioning). • Occupancy Detector is switching low wattage or LED loads- Fit Capacitor NL5705A across switch live and neutral of load. • Occupancy Detector is switching a contactor and the contactor chatters or stays ON - Fit a NL5705A capacitor across the switch live and neutral of the contactor coil.

THIS IS AN ALL MASTER SYSTEM

DO NOT USE SLAVES WITH THIS PRODUCT. THESE OCCUPANCY DETECTOR'S CAN ONLY BE WIRED WITH EACH OTHER. PLEASE BE AWARE OF THE CHANGES TO THE TERMINALS FROM PREVIOUS CEILING MOUNT TIMERS.

L IN	L OUT		N	OLD TERMINALS
L IN	L OUT	N	N	NEW TERMINALS

Do not wire neutrals unless the terminals are marked with an N.

IMPORTANT NOTICE

All wiring should be carried out by a competent person or a qualified electrician and should be fitted to IEE Wiring regulations BS7671. The circuit should be isolated before carrying out any work. Failure to adhere to the instructions will invalidate the warranty.