



Reliable and vandal resistant, the IP65 rated range of LED bulkheads is exceptionally robust and versatile to use.

IP65

IK10

LED

Lighting
CONTROL
Options

5 YEAR
Warranty

FEATURES

- Available in two sizes - Ø 300 and 218mm
- Robust Polycarbonate body in black or white (Ø218 only in white)
- Two styles of trim available for the large Drake (sold separately)
 - decorative trim for smarter look
 - eyelid trim to avoid light pollution
- Opal Polycarbonate diffuser
- Energy efficient LED gear tray with a life span of 30,000 hours (L70)
- IP65 – formed-in-place foam gasket protects against dust and water
- Exceptionally robust and vandal resistant due to rigidly constructed base, screwed-down diffuser and flush fit to fixing surface
- Available Options: Standard or 3hr Emergency (Ø300 only)

SIMPLE TO INSTALL AND USE

- Hinged LED gear tray for swift and easy installation (Ø300 only)
- BESA box fixing points for easy cable entry
- Wall or ceiling mountable
- Exterior or interior use

TYPICAL APPLICATIONS

Ideal for internal and external applications where durability and adaptability is important.

- Housing associations
- Sports areas
- Walkways and corridors
- Car parks and loading bays



Designed and Manufactured in the UK



DRAKE



Drake - Large Ø300mm



Drake - Large with Trim Ø308mm



Drake - Large with Eyelid Ø308mm



Drake - Small Ø218mm

TECHNICAL INFORMATION

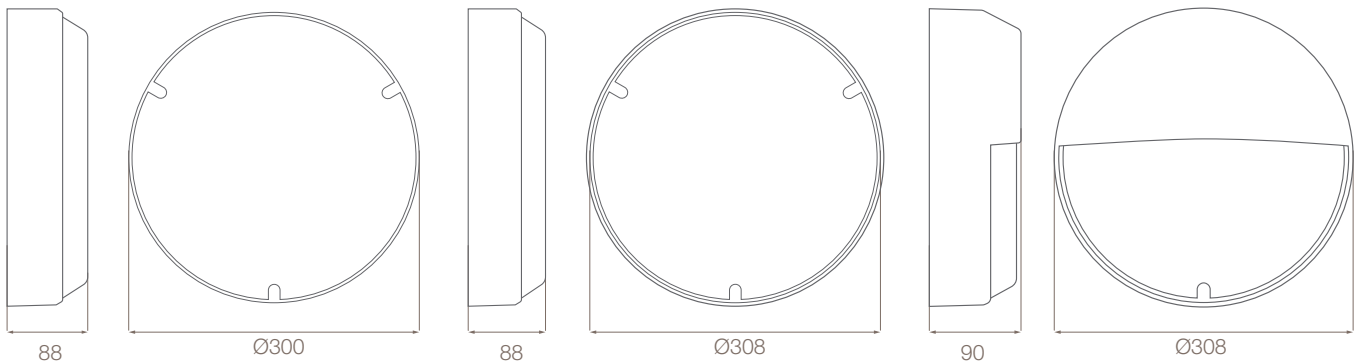

Dimensions:

Large:
Ø 300 x 88mm

Large with Trim:
Ø 308 x 88mm

Large with Eyelid:
Ø 308 x 90mm

Small:
Ø 218 x 95mm

Mounting type:



Wall



Interior



Ceiling



Exterior

Weight:

Small: 1.1kg
Large: 1.3kg

Base Colour Options:

- White base
RAL9016 Textured Matt Finish
- Black base
RAL 9005 Textured Matt Finish

Diffuser Options:

- Opal Diffuser

LIGHT DISTRIBUTION

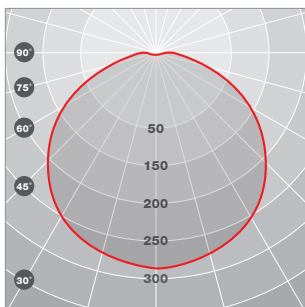

cd/m² η = 100%
— C0 / C180 — C90 - C270

Opal diffuser

Photometric files at www.fernhoward.com

STANDARDS

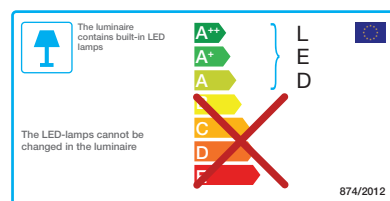

DRAKE

FH Part No.	FH Range	Size	Description	Finish Diffuser Option	Lumen Output (Lm)	System Power (W)	Efficacy (Lm/W)	3hr Emergency	IP Rating	Lumen Output in EM (LM)
LBHD12IP65840BK	Drake	Large	LED Bulkhead	Opal	1,300	13	100		65	
LBHD12IP65840BKE3	Drake	Large	LED Bulkhead	Opal	1,300	13	100		65	
LBHD12IP65840WH	Drake	Large	LED Bulkhead	Opal	1,300	13	100	EM	65	250
LBHD12IP65840WHE3	Drake	Large	LED Bulkhead	Opal	1,300	13	100	EM	65	250
LBHDWHTRIM12	Drake - Large Trim, White		Trim							
LBHDBKTRIM12	Drake - Large Trim, Black		Trim							
LBHDWHEYE12	Drake - Large Eyelid Trim, White		Trim							
LBHDBKEYE12	Drake - Large Eyelid Trim, Black		Trim							
LBHD7IP65840WH	Drake	Small	LED Bulkhead	Opal	900	10	90		65	

30,000
Hours
L70

>80
CRI (Ra)

4,000K
Colour
Temperature



Fern-Howard products are manufactured in the UK at our modern factory in Alton, Hampshire. Luminaires are manufactured and tested in accordance with BS EN60598. Incorporated control gear and components comply with BS/VDE standards. Luminaires are tested in accordance with IES LM-79-08.